

УДК 539.12.04; 539.1.08

Oskomov V.V., Sedov A.N., Saduyev N.O., Kalikulov O.A., Kenzhina I.E.*, Utey Sh.B., Erezhep N.O., Bondarev E.N.

Institute of Experimental and Theoretical Physics of al-Farabi Kazakh National University, Almaty, Kazakhstan

UNIVERSAL DATA COLLECTION SYSTEM FOR MEASURING THE INTENSITY OF PULSED SIGNALS

Abstract. This article describes the development and creation of a universal system of data collection to measure the intensity of pulsed signals. As a result of careful analysis of time conditions and operating conditions of software and hardware complex circuit solutions were selected that meet the required specifications: frequency response is optimized in order to obtain the maximum ratio signal/noise; methods and modes of operation of the microcontroller were worked out to implement the objectives of continuous measurement of signal amplitude at the output of amplifier and send the data to a computer; function of control of high voltage source was implemented. Preliminary program has been developed for microcontroller in its simplest form, which works on a particular algorithm.

Keywords: pulsed signals, universal data collection system, program technical complex

Introduction

Program-technical complex for data collection is designed to measure the intensity of pulsed signals of inputs of its information channels.

The following basic requirements should be provided in developing this system:

1. Stability of parameters over long periods of time (at least 8 months), such as amplification factor, voltage, detection efficiency.
2. Low power consumption.
3. Collection, storage and automatically transfer of information.
4. Reception, processing and delivery of the received information in a convenient way.

The use of microcontroller provides an extremely low total power consumption of the entire circuit and the small size of electronic circuit board. Data and control at electronic board from the control computer are provided by the second chip that implements algorithm for information exchange via USB interface. The use of this modern interface allows you to achieve high system performance in a temporary scan mode, and enables the use of system in absence of a separate power supply for its external electronic circuits, in relation to computer.

Electronic amplifier board with microcontroller and USB connection allows you to get a full ("oscillographic") registered signals from input channels while maintaining the data on your computer and their subsequent processing. In contrast to hardware pre-processing of signals when the apparatus determines that the right signal is registered and recorded only the fact of equipment operation.

Because the software and hardware system of data collection is assumed to be used in scientific experiments, it was decided to adapt the electronic amplifying board to a wide class of gas-discharge counters (Geiger-Muller, proportional counters, ionization chambers, etc.). In this case, the bandwidth required for this class of meter is from 0.1 kHz to 50 kHz, i.e. signals registration will go in a strip of low and medium frequencies.

Instruments and methods

First, we note that processes in gas counters are characterized by the order of several microseconds, the time between ADC counts should be of the order of several microseconds.

As a result of precise analysis of time and operating conditions of software and hardware complex circuit solutions that meet the following specifications were selected:

- frequency characteristic was optimized in order to obtain the maximum signal/noise ratio.

- methods and modes of operation of the microcontroller were worked out to implement the objectives of continuous measurement of signal amplitude at the output of amplifier and send the data to a computer.

- function of control of high voltage source was implemented.

The amplifier consists of a filter for high-voltage, high-voltage transition capacitor (C14), charge sensitive stage with capacitor 7.5 pF in feedback, and two identical stages with a voltage gain of about 10 (Figure 1).

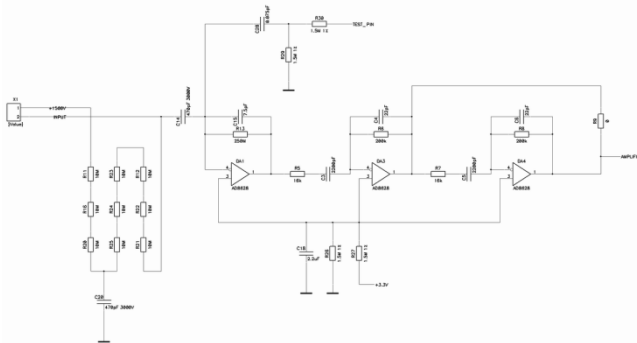

Figure 1 - Signal amplifier.

To be able to accurately tie recorded events in time, a highly stable temperature-compensated FOX914B generator was used with drift about one millionth.

Amplifier and all other circuits are powered from a ADP121 stabilizer for 3.3 volts, which is powered (5V) from USB.

The signal from amplifier is supplied to microcontroller ADC, which makes 100,000 counts per second with a resolution of 10 bits, or 80,000 counts per second with a resolution of 12 bits. Couples of byte counts are sent via USB to the computer through FT245R chip (Figure 2, 3).

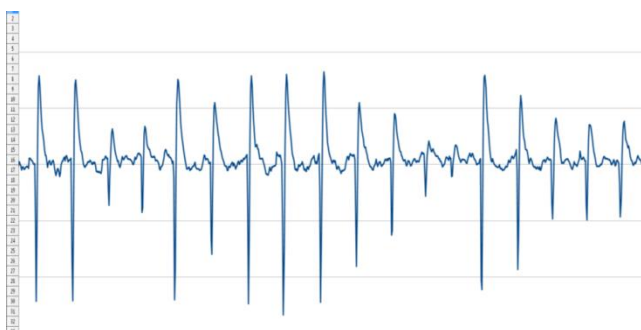

Figure 2 - The pulses on output of amplifier.

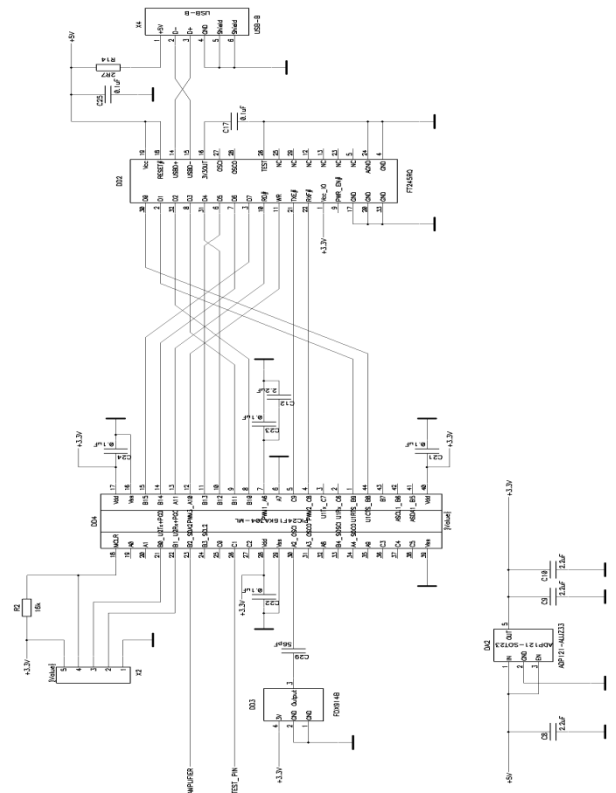

Figure 3 - Microcontroller with ADC and USB interface.

High voltage unit - a transformer with rectifier and electronic multiplying circuit of analysis and control, and the high voltage source is physically consisted of transistor switch, transformer and multiplying rectifier.

Microcontroller supply an impetus to the key of certain length (straight course) via a transformer and diode, one half of rectifier capacitors is recharged.

It also accumulates the energy in inductance of transformer. Then the key is turned off, the voltage due to transformer inductance changes sign (reverse), and the other half of capacitors recharges, followed by a relatively long pause.

In pause voltage diode rectifier is distributed uniformly and is half of the voltage level, about 100 volts. This provides a small leakage current of diodes, which is strongly dependent on the voltage.

During retrace microcontroller measures the flyback voltage. It is proportional to high voltage output of rectifier.

If the measured voltage is below set one microcontroller decreases by a small amount the duration of pause between pulses, thereby increasing the transmit power in rectifier. If the voltage is higher - the microcontroller increases the length of pause between pulses, the power transmitted to rectifier is reduced.

High-voltage unit supports a pre-determined set voltage and gives information on current consumption (Figure 4).

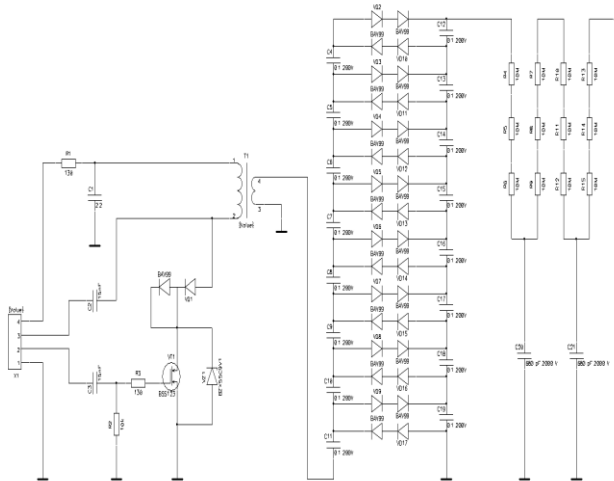

Figure 4 - Schematic diagram of a high voltage source for a wide range of gas-discharge counters

Results and discussion

The key is controlled by a microcontroller; the signal from primary winding of transformer is fed back to microcontroller for measurement.

Since multiplying rectifier is symmetrical, the inverter transfers energy to rectifier and on the direct course, and vice versa.

High voltage value is continuously measured with a high frequency at amplifier output, the last few counts are analyzed for the presence of a pulse. If it appears that pulse is there, that is, signal exceeds a certain threshold value, the drive is informed about another pulse, and the pulse value is used for correction of high voltage. It must be remembered that measured reverse voltage is not quite "measured high", depending on external influences the actual voltage may vary. In addition, the characteristics of gas-discharge counters may change over time, it is necessary that amplitude of pulse was approximately constant over time. Therefore,

the setting value can be adjusted according to analyzing values of pulses. In addition to correcting the high measured values scatter pulses is measured that provides diagnostic information about the "health" of counter and electronics.

It is suggested the number of pulses are transmitted to the outside "during the reporting period" on demand or at preset times that number, together with diagnostic information. It is necessary to transmit the minimum and maximum values of high-voltage pauses.

Conclusions

The preliminary program for microcontroller in its simplest form is working on following algorithm:

- Turns on ADC power and configures on a given frequency and accuracy of counts.
- Then in the next cycle is expected readiness of ADC reference. And as soon as the countdown is ready, the data is read from ADC and sent to USB chip.
- Again waiting for a new frame of reference.

In a more complex version (when setting up, for example), the program may apply test pulses to amplifier input, it may change the ADC mode.

Acknowledgments

The study was carried out under the support of grant #3838/GF4 of Ministry of Education and Science of Kazakhstan.

References

1. Nikolajchuk O. I. Sistemy maloj avtomatizacii/ M.: SOLON-Press, 2003. - 256 s.
2. Tavern'e K. PIC-mikrokontrollery. Praktika primeneniya: Per. s fr. M: DMK Press, 2003. - 272 s.
3. Kulakov V. Programirovanie na apparatnom urovne // Special'nyj spravocnik 2-e izdanie. - SPb.: Piter, 2003.- 874 s.
4. Bolski M. I. Jazyk programirovanija Si. Spravochnik: Per. s angl. — M.: Radio i svjaz', 1988. — 96 s.
5. Pejton A. Dzh., Bolsh V. Analogovaja jel-elektronika na operacionnyh usiliteljah / M.: BINOM, 1994. - 352 s.
6. Vinogradova N.A., Lietratov Ja.I., Sviridov E.V. Razrabotka prikladnogo programmno

obespechenija v srede LabVIEW: Uchebnoe posobie - M.: Izdatel'stvo MJeI. 2005. –51 s.
7 Mathanov H.N. Osnovy analiza jelektricheskikh cepej. Linejnye cepi.: Ucheb. dlja jel-

ektrotehn. i radiotehn. spec. 3-e izd. pererabot. i dop. –M.: Vyssh. shk., 1990. –400s.

Принято к печати 01.11.2016

В.В. Оскомов, А.Н. Седов, Н.О. Садуев, О.А. Каликулов, И.Е. Кенжина, Ш.Б. Утей, Н.О. Ережеп, Е.Н. Бондарев

Институт Экспериментальной и Теоретической физики Казахского Национального университета им. аль-Фараби, Алматы, Казахстан
kenzhina@physics.kz

УНИВЕРСАЛЬНАЯ СИСТЕМА СБОРА ДАННЫХ ДЛЯ ИЗМЕРЕНИЯ ИНТЕНСИВНОСТИ ИМПУЛЬСНЫХ СИГНАЛОВ

Абстракт: В данной статье описывается разработка и создание универсальной системы сбора данных для измерения интенсивности импульсных сигналов. В результате тщательного анализа по временным и эксплуатационным режимам программно-технического комплекса были выбраны схемотехнические решения, удовлетворяющие необходимым техническим условиям: частотная характеристика оптимизирована с целью получения максимального отношения сигнал/шум; отработаны методики и режимы работы микроконтроллера для реализации задачи непрерывного измерения амплитуды сигнала на выходе усилителя и отправки данных на компьютер; реализована функция управления источником высокого напряжения. Была разработана предварительная программа для микроконтроллера в простейшем варианте, которая работает по определенному алгоритму.

Ключевые слова: импульсные сигналы, универсальная система сбора данных, программно-технический комплекс.

V.V. Oskomov, A.N. Sedov, N.O. Saduyev, O.A. Kalikulov, I.E. Kenzhina *, Sh.B. Utey, N.O. Erezhep, E.N. Bondarev

Institute of Experimental and Theoretical Physics of al-Farabi Kazakh National University, Almaty, Kazakhstan
kenzhina@physics.kz

UNIVERSAL DATA COLLECTION SYSTEM FOR MEASURING THE INTENSITY OF PULSED SIGNALS

Abstract: This article describes the development and creation of a universal system of data collection to measure the intensity of pulsed signals. As a result of careful analysis of time conditions and operating conditions of software and hardware complex circuit solutions were selected that meet the required specifications: frequency response is optimized in order to obtain the maximum ratio signal/noise; methods and modes of operation of the microcontroller were worked out to implement the objectives of continuous measurement of signal amplitude at the output of amplifier and send the data to a computer; function of control of high voltage source was implemented. Preliminary program has been developed for microcontroller in its simplest form, which works on a particular algorithm.

Keywords: pulsed signals, universal data collection system, program technical complex

**В.В. Оскомов, А.Н. Седов, Н.О. Садуев, О.А. Каликулов, И.Е. Кенжина, Ш.Б. Утей,
Н.О. Ережеп, Е.Н. Бондарев**

*Әл-Фараби атындағы Қазақ Ұлттық университетінің эксперименталды және
теориялық физика ғылыми зерттеу институты, Алматы, Қазақстан*

kenzhina@physics.kz

ИМПУЛЬСТІК СИГНАЛДАРДЫҢ ҚАРҚЫНЫН ӨЛШЕУ ҮШІН МӘЛІМЕТТЕРДІ ЖИНАҚТАУШЫ ӘМБЕБАП ЖҮЙЕ

Аннотация. Ұсынылып отырған жұмыста импульстік сигналдардың қарқынын өлшеу үшін мәліметтерді жинақтаушы әмбебап жүйенің әзірленіп құрылуы баяндалған. Бағдарлы-техникалық кешеннің уақыттық және эксплуатациялық режимдері бойынша жете талдау нәтижесінде керекті техникалық шарттарды қанағаттандыратын схемотехникалық шешімдер таңдалды. Микроконтроллер үшін белгілі алгоритмде жұмыс істейтін нобайлық бағдарлама құрылды.

Маңызды сөздер: импульстік сигналдар, әмбебап деректер сатып алу жүйесі, бағдарламалық қамтамасыз ету және аппараттық кешен.